

Selectivity Gains and Energy Savings for the Industrial Phenyl Boronic Acid Process Using Micromixer/Tubular Reactors

V. Hessel,^{*,†} C. Hofmann,[†] H. Löwe,[†] A. Meudt,[‡] S. Scherer,[‡] F. Schönfeld,[†] and B. Werner[†]

Institut für Mikrotechnik Mainz GmbH, Carl-Zeiss-Strasse 18-20, D-55129 Mainz, Germany, and Clariant, D-65926 Frankfurt am Main, Germany

Abstract:

An industrial production-scale process currently conducted at Clariant site/Frankfurt, termed *Phenyl Boronic Acid Process* from here on, was investigated at laboratory-scale using two micromixer/tubular reactor configurations, being equipped with either a glass interdigital (for details see (1) Ehrfeld, W.; Golbig, K.; Hessel, V.; Löwe, H.; Richter, T. Characterization of mixing in micromixers by a test reaction: single mixing units and mixer arrays. *Ind. Eng. Chem. Res.* 1999, 38, (3), 1075–1082; (2) Hessel, V.; Hardt, S.; Löwe, H.; Schönfeld, F. Laminar mixing in different interdigital micromixers - Part I: Experimental characterization. *AIChE J.* 2003, 49, 566–577; (3) Hardt, S.; Schönfeld, F. Laminar Mixing in Different Interdigital Micromixers - Part 2: Numerical Simulations. *AIChE J.* 2003, 49, 578–584; (4) Herweck, T.; Hardt, S.; Hessel, V.; Löwe, H.; Hofmann, C.; Weise, F.; Dietrich, T.; Freitag, A. Visualization of Flow Patterns and Chemical Synthesis in Transparent Micromixers. In *Topical Conference Proceedings; IMRET 5, 5th International Conference on Microreaction Technology, AIChE Spring National Meeting; Matlosz, M., Ehrfeld, W., Baselt, J. P., Eds.; Springer-Verlag: Berlin, 2001; pp 215–229*) or a steel split-recombine mixer (for details see Schönfeld, F.; Hessel, V.; Hofmann, C. An Optimised Split-and-Recombine Micro Mixer with Uniform 'Chaotic' Mixing. *Lab Chip* 2004, 4, 65–69). The best yield of the microreactor investigations was 89%, exceeding the performance of the industrially employed stirred-tank process by nearly 25%. Moreover, the total amount of side and consecutive products was decreased from 10–15% to 5–10%. In addition to these yield improvements, the energy expenditure of the microreactor processing was also notably reduced, first of all because of carrying out the reaction at favorable ambient temperature. In contrast, the former batch process had to be carried out at cryogenic temperatures of –35 °C. Even at temperatures as high as 50 °C, a high selectivity was maintained when using the microreactor. As a further cause for energy savings, the higher purity of the product eliminated the need for distillation; in total therefore, only one heating–cooling cycle with reduced temperature difference was required for the microreactor process in contrast to the three cycles with large temperature differences used in conventional processing. Facing production and process liability issues, a specially made pilot-scale configuration was constructed entirely out of stainless steel components, among them a split–recombine caterpillar mixer having larger internal fluid channels than the interdigital glass

mixer. The new configuration allowed one to perform scale-up studies at throughputs as high as 10 L/h.

1. Introduction

During the past years, aryl and alkyl boron compounds have become very versatile synthetic building blocks which can be converted, e.g. via Suzuki coupling, to a multitude of economically very valuable fine chemicals in the fields of pharmaceuticals and agrochemicals⁶ (see also the original citations⁷ describing synthesis routes). Most prominent among such species, aryl and alkyl boronic acids have attained a virtually exponential increase in applications for drug synthesis. In addition, diaryl boronic acids gain attention due to their use as cocatalysts in olefin polymerisation or as precursors for Suzuki couplings, by which both aryl moieties can be transferred. Consequently, the conversion of aryl and alkyl Grignard reagents to give aryl and alkyl boron compounds is described by many publications. Given a strict control of reaction conditions, which however need to be optimised for each individual case, good yields can be obtained. Due to the latter reason, a drawback of the present processing routes is the large number of side products which are formed in amounts that depend strongly on the applied conditions.⁶ Following the hydrolysis of the reaction product mixtures, homo-coupling reactions are found yielding the corresponding biaryls and bialkyls. Moreover, boronic acids, triaryl or trialkyl boranes, and tetraaryl or tetraalkyl boronates

- (1) Ehrfeld, W.; Golbig, K.; Hessel, V.; Löwe, H.; Richter, T. Characterization of mixing in micromixers by a test reaction: single mixing units and mixer arrays. *Ind. Eng. Chem. Res.* 1999, 38, (3), 1075–1082.
- (2) Hessel, V.; Hardt, S.; Löwe, H.; Schönfeld, F. Laminar mixing in different interdigital micromixers - Part I: Experimental characterization. *AIChE J.* 2003, 49, 566–577.
- (3) Hardt, S.; Schönfeld, F. Laminar Mixing in Different Interdigital Micromixers - Part 2: Numerical Simulations. *AIChE J.* 2003, 49, 578–584.
- (4) Herweck, T.; Hardt, S.; Hessel, V.; Löwe, H.; Hofmann, C.; Weise, F.; Dietrich, T.; Freitag, A. Visualization of Flow Patterns and Chemical Synthesis in Transparent Micromixers. In *Topical Conference Proceedings; IMRET 5, 5th International Conference on Microreaction Technology, AIChE Spring National Meeting; Matlosz, M., Ehrfeld, W., Baselt, J. P., Eds.; Springer-Verlag: Berlin, 2001; pp 215–229*.
- (5) Schönfeld, F.; Hessel, V.; Hofmann, C. An Optimised Split-and-Recombine Micro Mixer with Uniform 'Chaotic' Mixing. *Lab Chip* 2004, 4, 65–69.
- (6) Koch, M.; Wehle, D.; Scherer, S.; Forstinger, K.; Meudt, A.; Hessel, V.; Werner, B.; Löwe, H. Verfahren zur Herstellung von Aryl- und Alkyl-Bor-Verbindungen in Mikroreaktoren. EP 1285924 (20.07.02), 21.08.01, 2001.
- (7) (a) Synthesis of phenyl boronic acid: Bean, F. R.; Johnson, J. R. Derivatives of Phenylboric Acid, Their Preparation and Action Upon Bacteria. II Hydroxyphenylboric Acids. *J. Am. Chem. Soc.* 1932, 54, 4415–4425. (b) 4-Ethoxyphenylboronic acid: Branch, G. E. K.; Yabroff, D. L.; Bettman, B. The Dissociation Constants of the Chlorophenyl and Phenetyl Boric Acids. *J. Am. Chem. Soc.* 1934, 56, 937–941.

* Author for correspondence. E-mail: hessel@imm-mainz.de.

† Institut für Mikrotechnik Mainz GmbH.

‡ Clariant.

are formed. With the exception of the latter class of charged compounds, expeditious purification procedures are thus required, decreasing the yield and increasing the production costs of the target product.

If aryl or alkyl boronic esters are the target product, only one equivalent of Grignard reagent needs to be reacted with the boronic acid precursor.⁶ However, via di-, tri- and tetra-fold substitutions by the metallo-organic reactant, biaryls/bialkyls, boronic acids, boranes, and even boronates are generated. If nonoptimal reaction conditions are run, the yield can be decreased in a dramatic manner. In many cases, purification of the crude products becomes a severe problem as well. The same holds for the synthesis of boronic acids, boranes, and boronates.

To decrease the amount of the before-mentioned side products, operation at low temperature is mandatory to prevent the primary products, obtained by the primary elemental reaction, from decomposition into the free boronic esters or halogenides.⁶ The latter species reacts with the metallo-organic reactant, in competition with the nonconverted boronic-acid precursor, and thereby decreases the yield. The same holds for higher arylated or alkylated products.

Good reaction conditions are found certainly below -25°C ; however, ideal performance with low and zero side products is produced only below -35 and -55°C , respectively.⁶ These temperatures cannot be achieved using simple cooling methods or brine cooling; rather they demand large energy expenditure and thus generate large costs. In conjunction with the need for an energy supply for refluxing during the Grignard reagent generation and for distillation of the crude product for removal of the solvent, several unwanted cooling-heating cycles follow each other, until the purified product is obtained by filtration or extraction at room temperature. Consequently, an uneconomic process is associated with large manufacturing costs.

Other drawbacks of the state-of-the-art processing arise from the need for an excess of the expensive boronic ester precursor.⁶ Even then, the reaction proceeds rather slowly, since the Grignard reagent has to be added dropwise and hence very slowly to remove heat fast enough to avoid hot spots. As a result, processing time is considerably longer than kinetics would predict. Thus, it is also usually preferred to work with rather dilute solutions. All these measures reduce the process performance.

The goal is, therefore, to develop a process using the same raw materials as for the conventional batch process which operates at temperatures exceeding -30°C and at favorably high reactant concentrations to give high yields of pure products with low contents of side products.

For this purpose, a micromixer/tube reactor configuration can be used.^{6,8} Continuous microchannel processing therein allows exact control over residence time and keeps the

temperature on a desired level, even when large heats of reaction are released.⁹⁻¹⁶ Moreover, by using micromixers fast liquid mixing down to the millisecond range can be achieved,^{2,3,17} thereby reducing the level of reaction with concentrations that have not been equilibrated, i.e., where an excess of one reactant may induce a secondary reaction. In a similar way, microreactors have been recently successfully applied to many organic reactions, e.g. to the Suzuki coupling,¹⁸ the Wittig reaction,¹⁹ the Stork enamine reaction,²⁰ and the fluorination of aromatics.^{21,22} Patent literature shows an increasing number of references on industrial microreactor-based chemical processes, containing experimental reports, e.g., on the acid cleavage in the framework of the Hock process, a chloroacetic acid process, and azo pigment formation (see ref 9b for more details and original citations).

2. The Phenyl Boronic Ester Process

The *Phenyl Boronic Ester Process* is one process among a class of similar reactions, all performing one or multiple arylation or alkylation steps on a trivalent boron precursor by use of a metallo-organic reactant. The boron precursor may contain halide, C_1 - C_5 alkoxy, $N,N(\text{C}_1$ - C_5 alkylamino), or C_1 - C_5 alkyl-thio moieties. The metallo-organic reactant is a magnesium-halide core substituted by a large variety of moieties, among them linear and branched C_1 - C_6 alkyl, phenyl or substituted phenyl groups, hetero-aryls, and many others.

The phenyl boronic ester process consists of a fast liquid reaction involving contacting of two reactants, phenylmagnesium bromide and boronic acid trimethoxy ester, each being dissolved in tetrahydrofuran (THF) to yield a liquid mixture. The arylation step is followed by hydrolysis to give the final product phenyl boronic acid. This product and by-

(8) Hessel, V.; Löwe, H.; Hofmann, C.; Schönfeld, F.; Wehle, D.; Werner, B. Process Development of a Fast Reaction of Industrial Importance Using a Caterpillar Micromixer/Tubular Reactor Setup. In *Topical Conference Proceedings; IMRET 6, 6th International Conference on Microreaction Technology, AIChE Spring National Meeting, March 11-14, 2002, New Orleans, LA; American Institute of Chemical Engineers: New York, NY, 2002; pp 39-54.*

(9) (a) Ehrfeld, W.; Hessel, V.; Löwe, H. *Microreactors*; Wiley-VCH: Weinheim, 2000. (b) Hessel, V.; Hardt, S.; Löwe, H. *Chemical Micro Process Engineering*; Wiley-VCH: Weinheim, 2004.
(10) Hessel, V.; Löwe, H. *Micro Chemical Engineering: Components - Plant Concepts - User Acceptance: Part I. Chem. Eng. Technol.* **2003**, *26*, 13-24.
(11) Jähnisch, K.; Hessel, V.; Löwe, H.; Baerns, M. *Chemistry in Microstructured Reactors. Angew. Chem., Int. Ed.* **2004**, *43*, (4), 406-446.
(12) Jensen, K. F. *Microreaction Engineering - Is Small Better? Chem. Eng. Sci.* **2001**, *56*, 293-303.
(13) Jensen, K. F. *Smaller, Faster Chemistry. Nature* **1998**, *393*, 735-736.
(14) Gavriilidis, A.; Angeli, P.; Cao, E.; Yeong, K. K.; Wan, Y. S. *Technology and Application of Microengineered Reactors. Trans. Inst. Chem. Eng.* **2002**, *80/A*, 3-30.
(15) Fletcher, P. D. I.; Haswell, S. J.; Pombo-Villar, E.; Warrington, B. H.; Watts, P.; Wong, S. Y. F.; Zhang, X. *Microreactors: Principle and Applications in Organic Synthesis. Tetrahedron* **2002**, *58*, 4735-4757.
(16) Haswell, S. T.; Watts, P. *Green Chemistry: Synthesis in Microreactors. Green Chem.* **2003**, *5*, 240-249.
(17) Löwe, H.; Ehrfeld, W.; Hessel, V.; Richter, T.; Schiewe, J. *Micromixing Technology. In Topical Conference Proceedings; IMRET 4, 4th International Conference on Microreaction Technology, AIChE Spring National Meeting, March 5-9, 2000, Atlanta, GA; American Institute of Chemical Engineers: New York, NY, 2000; pp 31-47.*
(18) Skelton, V.; Greenway, G. M.; Haswell, S. J.; Styring, P.; Morgan, D. O. *Micro Reactor Synthesis: Synthesis of Cyanobiphenyls Using a Modified Suzuki Coupling of an Aryl Halide and Aryl Boronic Acid. Microreaction Technology. In Topical Conference Proceedings; IMRET 5, 5th International Conference on Microreaction Technology, AIChE Spring National Meeting; Matlosz, M., Ehrfeld, W., Baselt, J. P., Eds.; Springer-Verlag: Berlin, 2001; pp 235-242.*

Scheme 1. Series of elementary reactions of the *Phenyl Boronic Acid Process* and subsequent hydrolysis

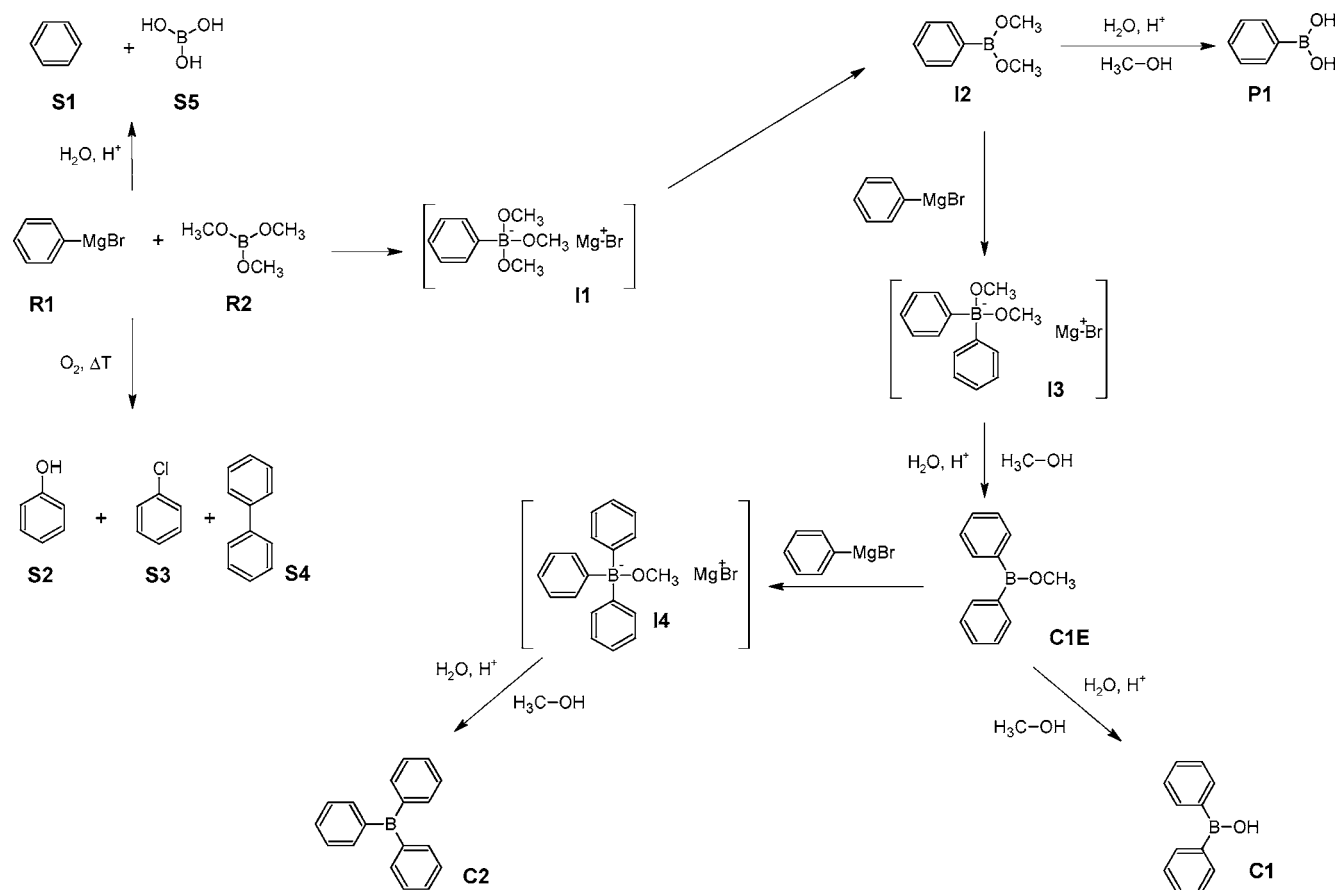

products are abbreviated as follows (as given in Scheme 1):

P1: phenyl boronic acid	(product 1)
R1: phenylmagnesium bromide	(reactant 1)
R2: boronic acid trimethyl ester	(reactant 2)
I1: phenyl trimethoxy boronium magnesium bromide	(intermediate 1)
I2: phenyl boronic ester dimethyl ester	(intermediate 2)
I3: diphenyl dimethoxy boronium magnesium bromide	(intermediate 3)
I4: triphenyl methoxy boronium magnesium bromide	(intermediate 4)
S1: benzene	(side product 1)
S2: phenol	(side product 2)
S3: chlorobenzene	(side product 3)
S4: biphenyl	(side product 4)
S5: boric acid	(side product 5)
C1: diphenyl boronic acid	(consecutive product 1)
C2: triphenylborane	(consecutive product 2)
C1E: diphenyl boronic acid methyl ester	(ester of consecutive product 1)

The total process actually consists of a number of elementary reactions which also give rise to side products, especially to higher arylated boron species which reduce the

yield of the target product and which generate purification problems. The two reactants, phenylmagnesium bromide **R1** and boronic acid trimethoxy ester **R2**, form a charged intermediate **I1**, phenyltrimethoxyboronium salt. This reacts to a second intermediate **I2**, the phenyl boronic acid dimethoxy ester. This intermediate is then hydrolysed to give the target product phenyl boronic acid **P1**.

A number of additional reactions decrease the selectivity and yield. First, the reactants phenylmagnesium bromide and boronic acid trimethoxy ester are labile to moisture. Hydrolysis results in the formation of the side products, reactants benzene **S1** and boric acid **S5**. By more complex pathways, not depicted in detail in Scheme 1, three other known side products are generated, phenol (**S2**), chlorobenzene (**S3**), and biphenyl (**S4**). Second, diphenyl boronic acid methoxy ester,

- (19) Skelton, V.; Greenway, G. M.; Haswell, S. J.; Styring, P.; Morgan, D. O.; Warrington, B. H.; Wong, S. *Micro Reaction Technology: Synthetic Chemical Optimisation Methodology of Wittig Synthesis Enabling a Semi-Automated Microreactor for Combinatorial Screening*. In *Topical Conference Proceedings; IMRET 4, 4th International Conference on Microreaction Technology*, AIChE Spring National Meeting, March 5–9, 2000, Atlanta, GA; American Institute of Chemical Engineers: New York, NY, 2000; pp 78–88.
- (20) Sands, M.; Haswell, S. J.; Kelly, S. M.; Skelton, V.; Morgan, D.; Styring, P.; Warrington, B. The investigation of an equilibrium dependent reaction for the formation of enamines in a microchemical system. *Lab Chip* **2001**, *1*, 64–65.
- (21) Chambers, R. D.; Spink, R. C. H. Microreactors for elemental fluorine. *Chemical Communications* **1999**, (10), 883–884.
- (22) Jähnisch, K.; Baerns, M.; Hessel, V.; Ehrfeld, W.; Haverkamp, W.; Löwe, H.; Wille, C.; Guber, A. Direct fluorination of toluene using elemental fluorine in gas/liquid microreactors. *J. Fluorine Chem.* **2000**, *105*, (1), 117–128.

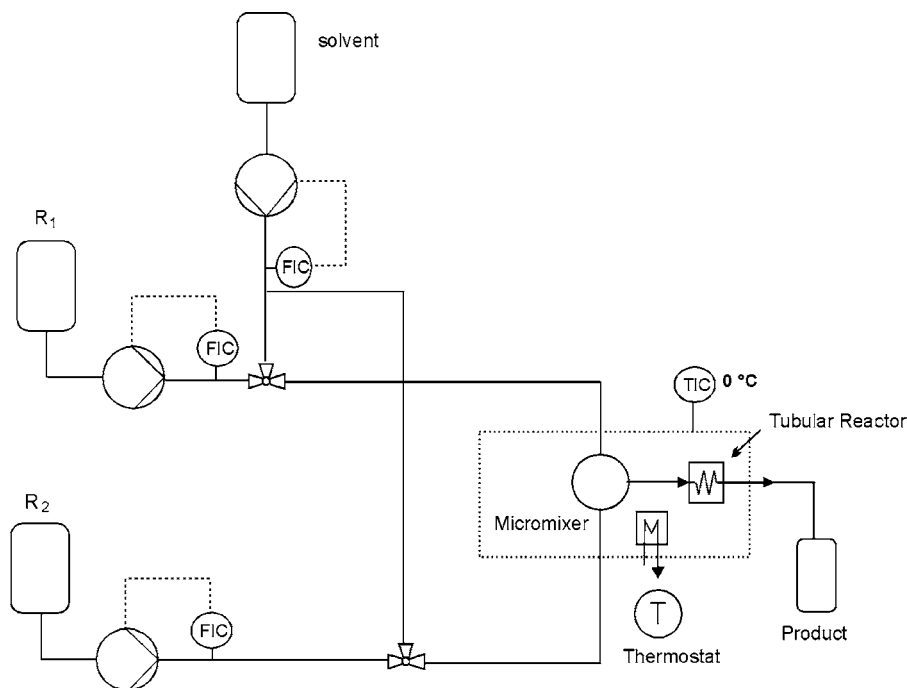

Figure 1. Flow sheet of the laboratory-scale microreactor configuration of the *Phenyl Boronic Acid Process*, equipped with an interdigital micromixer.

C1E (the Ester of **C1**), and triphenyl borane, **C2**, are generated as consecutive products from **I2** by reaction with one or two equivalents phenylmagnesium bromide, respectively.

The intermediates **I1** and **I3**, however, precipitate in the course of the reaction. These species are dissolved by subsequent reaction to the product **P1** and the consecutive product **C1** (according to Scheme 1).

A low content of diphenyl boronic acid **C1** is, in particular, important for an efficient product separation of phenyl boronic acid. **C1** and all the side products remain in solution after the end of the process and cannot be separated simply by filtration.

3. Experimental Section

Recording of Streamlines (Flow-Pattern and Fouling Visualizations). Mixing was recorded by using digital recording with an optical microscope Stemi 2000-C, Zeiss Göttingen, Germany (magnification $13\times \dots 100\times$) equipped with a video camera 3CCD Color Video Camera Power HAD, DX-950P, Sony, Tokyo, Japan (resolution $768 \times 576 \times 24$).

Apparatus. (a) *Industrial Laboratory and Production Batch Configurations.* The laboratory batch configuration at the Clariant site was based on a stirred four-necked glass 2-L flask (with the German standard ground joints 2×14.5 ; 1×29 ; 1×45) processing a liquid volume of about 1.5 L. The impeller had a crescent-shaped Teflon flat blade (blade length and width 10 and 2 cm, respectively) and a clearance (distance to flask bottom) of 1 mm (no baffles were applied). The impeller rotational speed was 60–150 rpm. The glass flask was cooled, if required, and the gas chamber in the flask above the stirred solution was purged with nitrogen. About 10–20% of the total volume of the solvent was filled into the flask before starting the reaction. From then, two

separate reactant solutions were dosed into the flask under the stirring conditions described above.

The industrial batch production plant cannot be described here, as this relates to undisclosed internal know-how of Clariant.

(b) *Laboratory-Scale Configuration.* Two reservoirs contain the anhydrous THF solutions of the reactants. A third reservoir contains pure anhydrous THF for purging of the processing line and, possibly, for on-line dilution of the two reactant streams (see Figure 1). Double-piston pumps (KP 2000, Desaga Sarstedt-Gruppe, Wiesloch, Germany) with flow-indicated control fed the solutions from the reservoir to a mixer/tubular reactor. A triangular interdigital micromixer made of a specialty glass (see Table 1) was applied for most of the experiments, which were carried out at IMM. In one case a caterpillar minimixer was used; in a few further cases, follow-up investigations were performed at the Clariant site with a steel slit interdigital micromixer (see the Results and Discussion section). The use of a conventional tube of mesoscale diameter (2.4 mm i.d.), rather than a microchannel reaction device such as a microheat exchanger, was mandatory as precipitation inevitably occurs during the reaction. The whole reaction unit, mixer and tube, was submerged into a water heating bath which is part of a thermostat sensing and controlling the temperature. The product is collected by pouring the reactant stream out of the tube into a beaker.

(c) *Pilot-Scale Configuration.* The pilot-scale configuration was developed with aim to have a scaled-out version of the laboratory configuration. Ideally, one would have used purely the numbering-up concept for scale-up, i.e., the repetition of many parallel interdigital units and the same number of tubes attached. However encountering the known fouling problems and the accordingly severely limited operation time of the individual interdigital mixer units, it

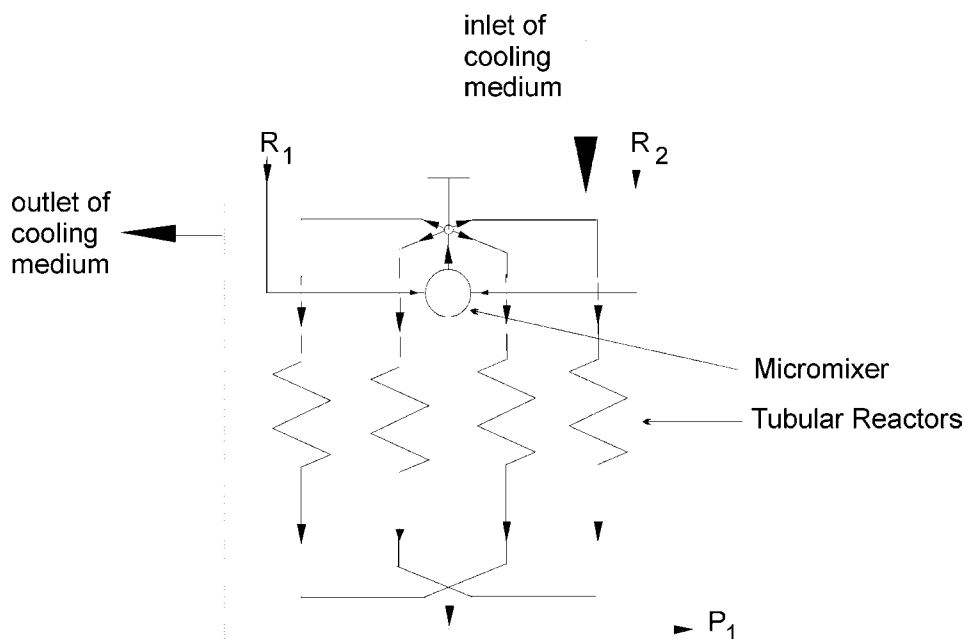

Figure 2. Flow sheet of the laboratory-scale microreactor configuration of the *Phenyl Boronic Acid Process*.

Table 1. Specifications and dimensions of the glass triangular interdigital micromixer

triangular interdigital micromixer: characteristic properties	specifications
mixer construction material	Foturan, a commercial specialty glass made by Schott Desag AG (Grünenplan, Germany) and licensed to mgt mikroglas technik Mainz AG (Mainz, Germany). SiO ₂ = 75–85%, Li ₂ O = 7–11%, K ₂ O = 3–6%, Al ₂ O ₃ = 3–6%, Na ₂ O = 1–2%, ZnO = 0–2%, Sb ₂ O ₃ = 0.3%, Ag ₂ O = 0.1%, CeO ₂ = 0.015%.
mixer feed channel width and depth; fin walls separating the feed channels	60 μm; 150 μm; 30 μm
total number of feed channels	2 × 15
triangular chamber: initial width; focused width; depth; focusing length; mixing length; focusing angle; focusing factor	3.25 mm; 500 μm; 150 μm; 8 mm; 19.4 mm; 20°; 6
device outer dimensions: length, width, and thickness (bonded glass plates only, no frame)	76 mm; 26 mm; 2.3 mm

stood to reason that compromises had to be made. Following a procedure which turned out to be successful for a Merck microreactor-based production plant,²³ the micromixer was replaced by a minimixer of larger internal dimensions. A so-called caterpillar mixer was chosen, since this device relies on a split–recombine principle, which on ideal flow conditions (low *Re* number) gives multilamination patterns, i.e., preserves the fluid dynamics utilised by the interdigital micromixer.⁵ Only recently, it was found that deviations occur from this ideal due to imperfections of the mixer geometry and that under the conditions described in this section secondary-flow patterns may superpose the multilamination pattern.⁵ From former studies concerning calcium carbonate precipitation, which is an instantaneous forced precipitation, it was known that this mixer has a better performance for fouling-sensitive processes than interdigital micromixers.²⁴

Due to improved construction (all components being solidly mounted on a rig) and the choice of the hard steel material (instead of glass and polymer) the pilot-scale configuration is more robust and more user-friendly. By means of a 5/2-way valve four tubular reactors acting as delay loops can be alternately set into operation. In addition, one of the tubes was replaced by another, yielding finally a choice of five tubes which were operated. These tubes differ in inner diameter (0.7, 3.8, 4.8, 9.3, and 21.2 mm; all at a length of 1000 mm) and hence residence time. The whole reaction unit, including mixer and the four tubes, are submerged into a cylinder completely filled with a cooling/heating medium attached to a thermostat (see Figure 2).

Microchannel Devices. (a) *Slit and Triangular Interdigital Micromixers.* As the micromixer, initially a triangular interdigital glass device was applied (see Table 1) which was

(23) Krummradt, H.; Kopp, U.; Stoldt, J. Experiences with the Use of Microreactors in Organic Synthesis. In *Topical Conference Proceedings; IMRET 3, 3rd International Conference on Microreaction Technology*, AIChE Spring National Meeting; Ehrfeld, W., Ed.; Springer-Verlag: Berlin, 2000; pp 181–186.

(24) Schenk, R.; Donnet, M.; Hessel, V.; Hofmann, C.; Jongen, N.; Löwe, H. Suitability of Various Types of Micromixers for the Forced Precipitation of Calcium Carbonate. In *Topical Conference Proceedings; IMRET 5, 5th International Conference on Microreaction Technology*, AIChE Spring National Meeting; Matlosz, M., Ehrfeld, W., Baselt, J. P., Eds.; Springer-Verlag: Berlin, 2001; pp 489–498.

Table 2. Specifications and dimensions of the steel slit interdigital micromixer

slit interdigital micromixer: characteristic properties	specifications
mixer construction material	housing: stainless steel (1.4571; SS 316 Ti) mixer inlay: nickel on copper base
mixer feed channel width and depth; fin width (separating the channels) total number of feed channels	40 μm ; 300 μm ; 30 μm 2 \times 25
slit depth in steel housing	60 μm
tubing attached to slit: diameter	500 μm
device outer dimensions: diameter and height	20 mm; 16.5 mm

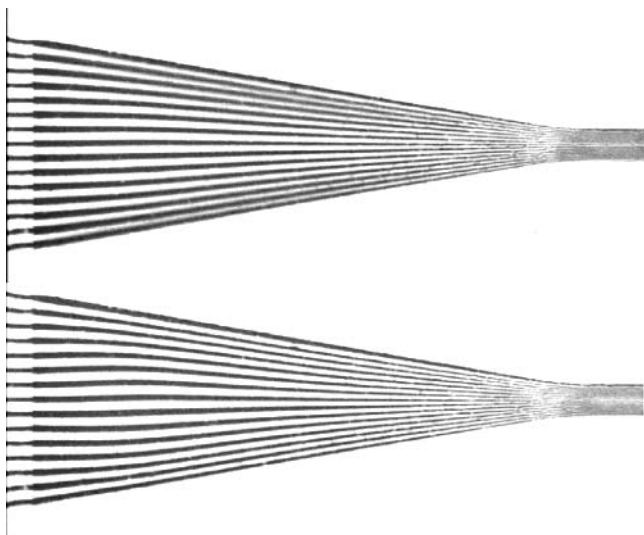

Figure 3. Identical multilamination flow patterns obtained at low (100 mL/h, bottom image) and high (2000 mL/h, top image) volumetric flow rate in the glass interdigital micromixer. The imaging is achieved by using aqueous test solutions, one of them containing acid blue as dye.

jointly developed by the Institut für Mikrotechnik Mainz GmbH AG (IMM), Mainz/Germany and mgt mikroglas technik Mainz, Mainz/Germany and is meanwhile a commercial product of mgt mikroglas technik Mainz.^{2,17} This mixer relies only on a multilamination flow pattern, undisturbed by eddies and wakes (see Figure 3).¹⁷ This was regarded to be crucial so as to keep fouling as low as possible. By means of geometric focusing of the multilamellae stream, fast mixing is achieved. The initial lamellae width of 90 μm is focused by a factor of 6–15 μm . Glass was chosen as construction material to enable simple visual inspection of the extent of fouling within the device. This mixer is known to achieve liquid mixing within about 100 ms for a mixing degree of 99%, assuming water-like systems at room temperature and a diffusion constant typical for organic molecules (10^{-9} m²/s).^{2,3}

In later follow-up studies at the Clariant site, it was desired to change the material from glass to steel. Accordingly, the off-the-shelf product standard slit interdigital micromixer (SSIMM) was chosen (see Table 2).¹

(b) *Caterpillar Minimixer.* For the minimixer, a split–recombine stainless steel mixer (the caterpillar mixer) was used (see Figure 4)⁵ (see also ref 24). The name of this mixer is derived from its characteristic 3D geometry consisting of ascending and descending steps on the top and the bottom of a minichannel. Their impact on the flow of two inserted

fluids results in a repeated splitting, reshaping, and recombination, thereby decreasing the lamellae width and generating a multilamellae pattern.

The caterpillar minimixer is a commercial product of IMM (CPMM-R1200). Recently, a simulation study showed that at high volumetric flow rates (and consequently high *Re* numbers) secondary-flow patterns become active and deviations from the ideal multilamination pattern occur due to shear and friction forces.⁵ As a consequence, a considerably improved design has been proposed and realised (a second-generation caterpillar minimixer) which is especially suited for mixing of highly viscous solutions,⁵ which was, however, not used for the synthesis described here (see Table 3).

Experimental Protocols. (1) *Conventional Batch Synthesis.* THF solutions ($c = 0.5$ mol/L) of the reactants phenylmagnesium bromide and boronic acid trimethoxy ester are dosed simultaneously in a round flask which is filled with solvent (10–20% of the total volume), held at a temperature of 20 °C. The speed of dosing is chosen in such a way that the temperature is kept at 20 ± 5 °C. For a total volume of 1.5 L, for example, 22 min are needed. A total yield of all products (including side products) amounts to 83% (see Table 4). By HPLC analysis, a content of diphenyl boronic acid of 13.8% and a content of triphenyl borane of 1.1% is determined.

(2) *Laboratory-Scale Continuous Microreactor Synthesis.* Anhydrous THF solutions ($c = 0.5$ mol/L, puriss. p.a. > 99.5%, Aldrich no. 87368, Taufkirchen/Germany) of the reactants phenylmagnesium bromide (2 mol/L in THF, Aldrich no. 22,444-8, Taufkirchen/Germany) and boronic acid trimethyl ester (99.5%, Aldrich no. 44,399-9, Taufkirchen/Germany) were filled in vessels (of a volume of typically 1 L), stored under dry nitrogen, and cooled there to reaction temperature. From a third reservoir, the whole laboratory-scale apparatus was flushed with anhydrous THF. By use of double piston pumps, the reactant solutions were fed from the reservoirs into a triangular interdigital micromixer which was connected to a PTFE tube (i.d.: 2 mm) of 70 cm length. Both the mixer and the tube were inserted into a cooling/heating bath filled with water. The reaction solutions were poured into a stirred beaker filled with water with a pH of 4.5 (50 mg water; 30–60 s insertion of reaction product stream, time being dependent on volume flow, and weighing of that charge; addition of 1.5 g concentrated H₂SO₄). THF is removed from the solvent mixture by smooth distillation under reduced pressure at 100 mbar. After cooling to 0 °C,

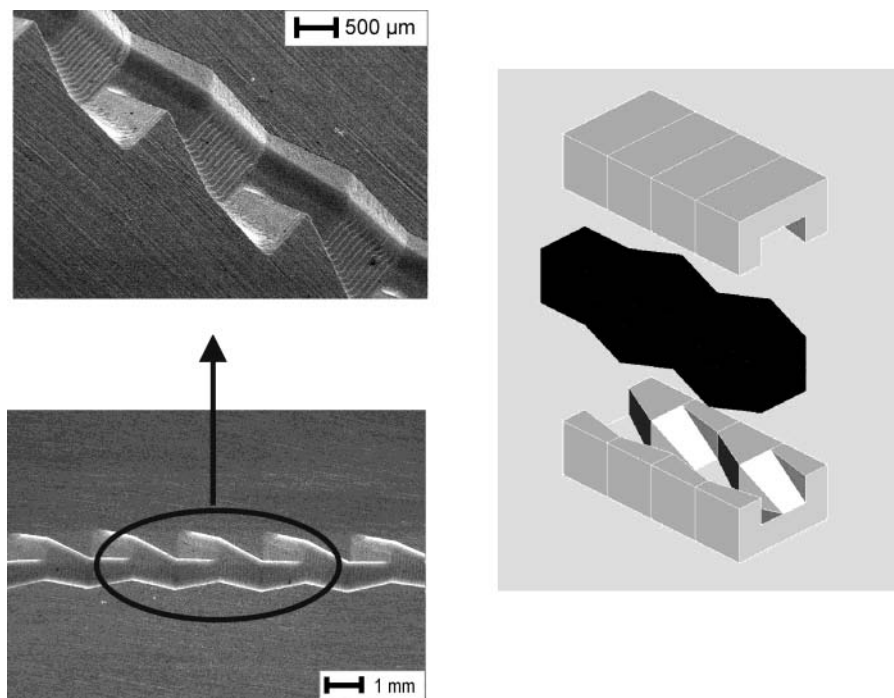

Figure 4. Schematic of the caterpillar minimixer and SEM images of parts of the microchannel structure.

Table 3. Specifications and dimensions of the steel caterpillar minimixer

caterpillar minimixer: characteristic properties	specifications
mixer construction material	stainless steel 1.4571 (SS 316 Ti)
number of plates needed to form minimixer channel	2
minimixer channel: initial width; maximum width	1200 μm ; 2400 μm
minimixer channel (both plates): initial depth; maximum depth	1200 μm ; 1700 μm
microstructure in one plate: initial depth; maximum depth	600 μm ; 850 μm
minimixer stage: length	2400 μm
number of mixing stages	8
total length of caterpillar minimixer	19.2 mm
device outer dimensions	50 mm \times 50 mm \times 10 mm

Table 4. Yields obtained for the target product phenyl boronic acid and of the consecutive product diphenyl boronic acid of the Phenyl Boronic Acid Process using a laboratory-scale and an industrial batch processing

reactor type	T [$^{\circ}\text{C}$]	c [mol/L]	τ [min]	$Y_{\text{crude product}}$ [%]	HPLC a/a purity [%]	$Y_{\text{pure product}}$ [%]	$Y_{\text{diphenyl boronic acid}}$ [%] HPLC a/a
laboratory-scale batch (1.5 L)	20	0.5	22	83.0	85.1	70.6	13.8
industrial batch	20	2.0	— ^a	— ^a	— ^a	65.0	— ^a

^a Not disclosed.

the product is precipitated, isolated by filtration, and dried. HPLC analysis was then performed.

The reaction was carried out at four temperatures, -12 , 0 , 22 , and 50 $^{\circ}\text{C}$, and at four total volumetric flow rates, 200, 500, 1000, and 1500 mL/h. Since a constant length of the PTFE tube was used, the variation of the volumetric flow rate changed the residence time too. Thereby, the following residence times were achieved: 200 mL/h: 40 s, 500 mL/h: 16 s, 1000 mL/h: 8 s, 1500 mL/h: 5 s. The yields of the product and of the side and consecutive products were determined by HPLC. The operation of the laboratory-scale configuration was limited to a few minutes for each run, since plugging by precipitation of the charged tetravalent intermediates occurred.

(3) *Preparative Continuous Microreactor Synthesis.* For isolation of the product phenyl boronic acid in quantitative amounts, the laboratory-scale configuration was used; however, the interdigital micromixer was exchanged against a caterpillar minimixer. As such, much longer operational times in the range of several 10s of minutes could be achieved without plugging. The minimixer was connected to a PTFE tube of 1/4" diameter with residence times equal to the ones reported above. This was achieved by setting the volumetric flow rate higher to 10 L/h with the additional benefit of having advanced mixing quality due to higher flow velocities. The other process parameters, concentration and temperature, were chosen equal to those given in the protocol (2).

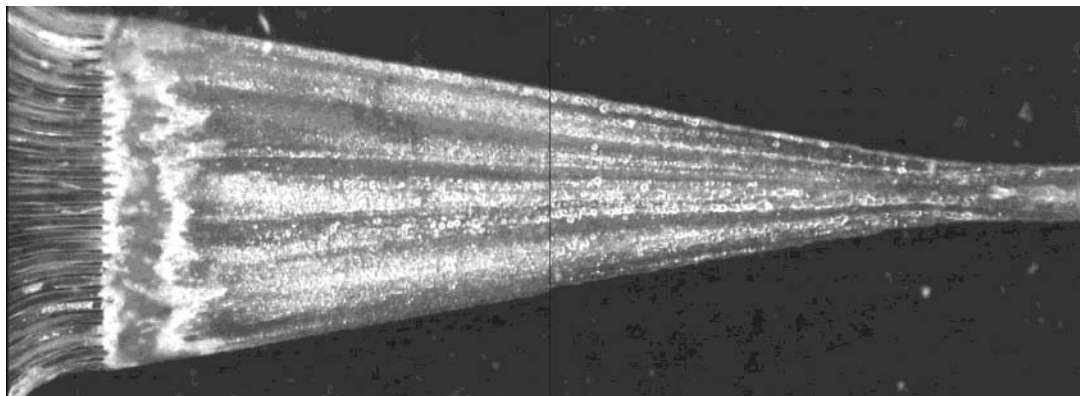

Figure 5. Precipitate formation composed of intermediate products of the *Phenyl Boronic Acid Process* along the interfaces between the multilaminated lamellae (Figure 5 is actually composed of two separately taken photos).

(4) *Pilot-Scale Continuous Microreactor Synthesis.* Operation was carried out in a scaled-out pilot-scale configuration with a steel caterpillar minimixer being connected to four stainless steel tubes via a 5/2-way valve. The pilot-scale synthesis was conducted at residence times of 5, 10, 26, and 120 s at temperatures of 10 and 20 °C. In a second set of experiments, residence times were set to 1, 5, 10, 26 s at 30 and 40 °C. The concentration of the THF solution was 0.5 mol/L, equal to that in the protocols (2) and (3).

4. Results and Discussion

Experiments Using a Laboratory-Scale Batch: Protocol (1). The results of the laboratory-scale and industrial batch processing, both being performed at the Clariant site, are given in Table 4. The yields of pure product for both apparatuses are 71 and 65%, respectively. Reducing the reactor volume and the concentration of the reactants leads to increased yield of pure phenyl boronic acid. In both cases, significant amounts of side and consecutive products are generated, leading to large expenditure for purification by distillation and filtration/extraction.

The beneficial effect of reducing the flask volume is a result of the better stirring of smaller volumes and hence the correspondingly enhanced mass and heat transfer. Albeit the type of laboratory batch stirring chosen (for details see Experimental Section) is typical for industrial process development of such organic reactions, it has to be admitted that probably still better mixing is achievable when using more advanced and specialised batch-mixing equipment, i.e., it cannot be excluded that slightly better yields can be found for batch operation.

Experiments Using the Laboratory-Scale Configuration with the Interdigital Micromixers: Protocol (2). *Setting Fouling to an Acceptable Level.* Typically, 2 mol/L solutions of the reagents phenylmagnesium bromide and boronic acid trimethoxy ester were applied for the *Phenyl Boronic Acid Process* in the past, when being performed on an industrial level. However, operation with such highly concentrated solutions in the triangular interdigital mixer/tubular reactor resulted in intense fouling and even clogging. Therefore, it was attempted to dilute the solution to a concentration which can be properly handled. It turned out that a 0.5 mol/L reactant solution did fulfill this criterion.

Thereby, it was possible to operate the configuration for about 15 min. Thereafter, fouling was clearly visible in the interdigital mixer by white stripes composed of precipitates along the interfaces between the liquid lamellae (see Figure 5, see also ref 24). The 15-min processing time turned out to be long enough to gather reliable data on process yield.

For reasons of fouling, the postprocessing step, the hydrolysis of the product mixture, was not carried out using microfluidic devices; it was experimentally found that the introduction of the particle-containing solutions into a further set of tiny feed channels, e.g. of a second micromixer, inevitably resulted in clogging. In this context, it has to be emphasized that based on the experience of the authors care has to be taken when making general conclusions about the impact of particle-containing solutions on fouling in microdevices.²⁴ Naturally, the result is strongly dependent on type, concentration, and size of the particles as well as geometry and material of the microdevice.

Results of Laboratory-Scale Experiments. Table 5 presents all results obtained with the laboratory-scale configuration using the interdigital micromixer. The best result obtained amounts to 83% at a reaction temperature of 22 °C and a total volumetric flow rate of 1000 mL/h, which is equivalent to 8 s operation. This exceeds the performance of the formerly used batch production process by nearly 20%, although about half of all measurements differ by less than 5% and only two of eleven measurements differ by more than 10% from the maximum yield. Therefore, it can be stated that within the operation range investigated, from -12 to 50 °C and from 500 to 1500 mL/h the yield is relatively constant. In absolute terms the yield ranges from 65.5 to 83%. This is in contrast to the findings for the conventional batch operation, as outlined in the Introduction section.

Although in general the yields turned out to be relatively constant, there are exceptions, and it is also worthwhile to discuss the small variations of the yield as a function of the process parameters. Accordingly, in the following, the results first are represented as yield vs temperature plots at a given residence time to facilitate discussion of the corresponding dependency. Thereafter, representation is done as yield vs volumetric flow rate plots at a given temperature.

Temperature Variation. The yield vs temperature curves are characterized by a nearly constant behavior, actually

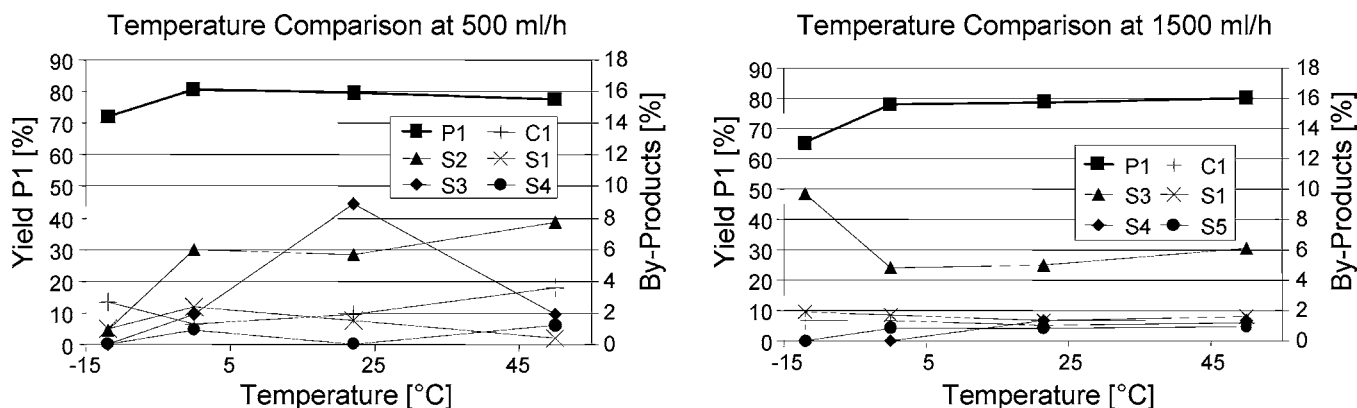

Figure 6. Yield of products as a function of temperature for the laboratory configuration with the interdigital glass micromixer.

Table 5. Yields obtained for the target product and side/consecutive products of the *Phenyl Boronic Acid Process* using the laboratory-scale configuration with the triangular glass micromixer

temperature flow rate [mL/h]	-12 °C				0 °C		22 °C			50 °C		
	200	500	1000	1500	500	1500	500	1000	1500	500	1000	1500
P1	51.9	72.0	80.7	65.5	80.6	78.4	79.6	83.2	78.7	77.4	82.1	80.1
C1	2.1	2.7	1.2	1.3	1.3	1.3	1.9	1.4	1.0	3.6	1.7	1.2
S2	10.2	0.9	7.9	9.7	6	4.8	5.7	5.8	5.0	7.7	7.0	6.1
S1	0.0	1.0	5.2	1.9	2.4	1.7	1.5	0.9	1.3	0.4	0.7	1.6
S3	0.0	0.0	0.0	0.0	1.9	0	8.9	1.9	1.3	1.9	1.9	1.3
S4	0.0	0.0	0.9	0.0	0.9	0.8	0.7	1.2	0.8	1.2	1.2	0.9

showing a small increase in yield from -12 to 0 °C and from there either a slightly constant or decreasing profile up to 50 °C (see Figure 6). Such a constant relationship is unusual for conventionally processed, strongly exothermic reactions such as the *Phenyl Boronic Acid Process*, typically showing a remarkable decrease in yield or selectivity when being carried out at high temperature. Similar favorable operation for such exothermic reactions using microreactors at high temperature was reported, e.g. for a metallo-organic synthesis²³ and for the hydrolysis of benzal chloride.⁴

Since variation of volumetric flow rate is equivalent to changing residence time for the given configuration with a constant tube length, it is to be expected that the maximum of the yield may be shifted to a higher temperature with increasing volumetric flow rate. Indeed, this is found at 500 mL/h (0 °C) and 1000 mL/h (22 °C), while a maximum is not observed in the temperature range investigated up to 50 °C when setting the volumetric flow rate to 1500 mL/h.

For a given residence time, the impact of temperature variation on the yield of side and consecutive products is notably low. This is confirmed by a second set of experiments at the Clariant site, which were performed after the initial laboratory-scale processing at IMM, not shown here (see ref 6).

Residence Time Variation. A striking feature of the laboratory configuration investigations is the nearly constant yield of **P1** as a function of volumetric flow rate for operation at the two higher temperatures at 22 and 50 °C (see Figure 7). Obviously, in these two cases even the shortest residence time is long enough to ensure completion of reaction. Moreover, this shows that mixing sensitivity is not pronounced. The latter probably is due to the focused multi-lamination flow pattern generated by the interdigital mixer,

being identical at all volumetric flow rates. By flow imaging using aqueous model solutions it is known that indeed stacked fluid layers are found for volumetric flow rates ranging from 5 to 1500 mL/h (see Figure 3 and ref 2).

In turn, the experiment at -12 °C is characterized by a maximum in the yield at a volumetric flow rate of 1000 mL/h. The decrease in yield at the highest volumetric flow rate of 1500 mL/h can be explained by setting a residence time too short for this low temperature. On the contrary, the decrease in yield for low volumetric flow rates, and corresponding long residence times, is currently not well understood. Since this decrease is not accompanied by a rise in side- or hydrolysis products, one currently has to rely on the working hypothesis that a new side product possibly was formed which is not detected by means of HPLC.

With the exception of the measurements made at the lowest temperature (-12 °C), the yields of the consecutive and side products **C1**, **S1**, and **S3** decrease with increasing volumetric flow rate, i.e., shorter residence time. The yield of the two other side products **S2** and **S4** is nearly constant.

As it is a common phenomenon that side reactions have higher activation energies than the main reaction, so their relative contribution is expected to increase with increasing temperature. Consequently, this means that control over residence time at elevated temperature is a proper way of reducing the amount of side products, which is confirmed by these experiments. At the Clariant site, a later, more detailed investigation on the dependency of the formation of the side product diphenyl boronic acid on the residence time was made, using the glass slit interdigital micromixer (see Table 6).

Concentration Variation. Doubling of the concentration to 1.0 mol/L shows that selectivity is decreased, i.e., the

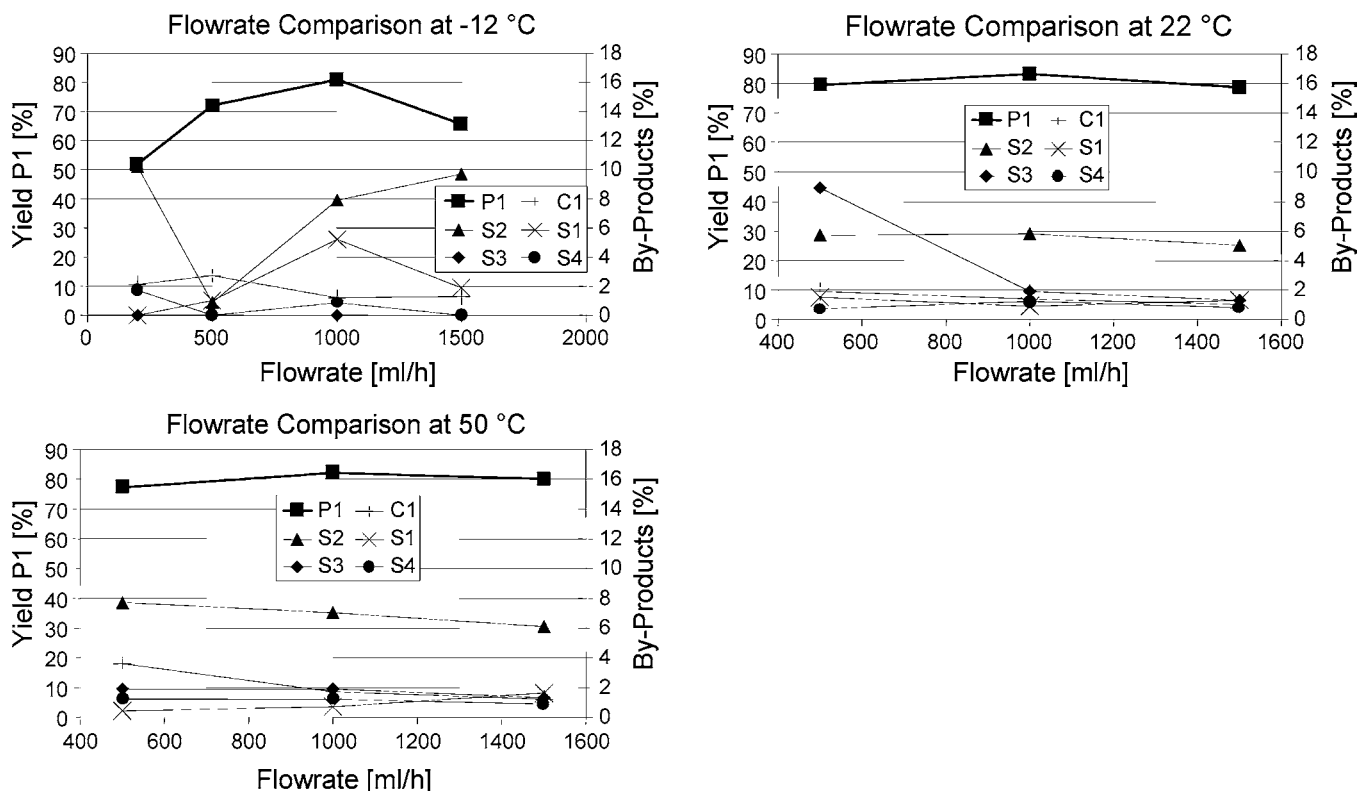

Figure 7. Yield of products as a function of volumetric flow rate, respectively residence time for the laboratory configuration with the triangular interdigital glass micromixer.

Table 6. Yields at various residence times obtained for the target product phenyl boronic acid and of the consecutive product diphenyl boronic acid of the *Phenyl Boronic Acid Process* using the laboratory-scale configuration with the slit interdigital glass micromixer

T [°C]	τ [s]	$Y_{\text{isolated product}}$ [%]	HPLC a/a purity [%]	$Y_{\text{diphenyl boronic acid}}$ [%] HPLC a/a
20	5	94.9	98.9	0.6
20	60	93.9	99.1	0.8
20	120	95.7	98.9	1.1
20	180	94.8	98.5	1.3

content of diphenyl boronic acid is decreased as well. This effect is, however, small compared to the difference in selectivity between any of the two microreactor experiments given in Table 7 (using the glass slit mixer) as compared to that of batch processing.

Experiments Using a Laboratory Configuration with the Caterpillar Minimixer: Protocol (3). *Corroboration of HPLC Results by Preparative Isolation of Product Phenyl Boronic Acid.* To substantiate the analytical results gained, the product **P1** was isolated by preparative means. However, since the time of operation of the laboratory configuration with the triangular interdigital micromixer was limited to about 30 min, it was not possible to obtain the desired quantitative amount of the product phenyl boronic acid which was set to 15 g.

Using this set of process parameters and equipment, the highest yield of 89% measured during the complete investigations was found (see Table 8). By preparative isolation of about 30 g product this result basically could be confirmed. A preparative yield of 81% was evaluated. Using a lower

volumetric flow rate of 2 L/h, however, resulted in a significant reduction of process performance. The decrease in yield to only 65% demonstrates that the caterpillar minimixer was operating in a flow range which probably caused nonoptimal mixing.

Both isolated preparative product samples had a high purity of 98–99%. The yield of the consecutive product **C1** (diphenyl boronic acid) was found to be 1–2%, the other impurities (**S1**–**S5**) only ranging in total below 0.1%. Again, similar findings were made in later investigations at the Clariant site (reaching purities up to 99.2%), demonstrating also that the impact of process temperature on the purity of the product is negligible, i.e., at a favourable large temperature range highly pure products can be achieved.

Although only two values for the yield were determined, both results point to a large impact of volumetric flow rate on the product yield for the caterpillar mixer. This finding is consistent with results obtained previously which analysed the corresponding dependency of the mixing quality. Results obtained with a competitive reaction system confirmed a steep increase of mixing quality with volumetric flow rate in the range of 100–5000 mL/h.²⁴

It is further known through CFD (computational fluid dynamics) simulation that nonideal flow splitting and recombination in the caterpillar mixer at low volumetric flow rates is the origin of this behaviour.⁵ In turn, at high volumetric flow rates a more intense mixing is observed which has characteristics of turbulent flow (see Figure 8).

Experiments Using the Pilot-scale Configuration with the Caterpillar Minimixer: Protocol (4). Table 9 lists all experiments made with the pilot-scale configuration using

Table 7. Yields at two concentrations of the reactant solutions obtained for the target product phenyl boronic acid and of the consecutive product diphenyl boronic acid of the *Phenyl Boronic Acid Process* using the laboratory-scale configuration with the slit interdigital glass micromixer

T [°C]	c [mol/L]	τ [s]	$Y_{\text{crude product}}$ [%]	HPLC a/a purity [%]	$Y_{\text{pure product}}$ [%]	$Y_{\text{diphenyl boronic acid}}$ [%] HPLC a/a
20	0.5	5	94.9	98.9	93.9	0.6
20	1.0	5	93.7	98.4	92.2	1.1

Table 8. Yields obtained for the target product and side/consecutive products of the *Phenyl Boronic Acid Process* using the laboratory configuration with the caterpillar steel minimixer

flow rate [mL/h]	2000	10000
mass of isolated crystals [g]	26.29	43.83
yield [%]	65	81
P1 Content [%]	98.9	98.2
C1 Content [%]	~1.0	~1.7
total content of S1, S2, S3, S4 [%]	<0.1	<0.1

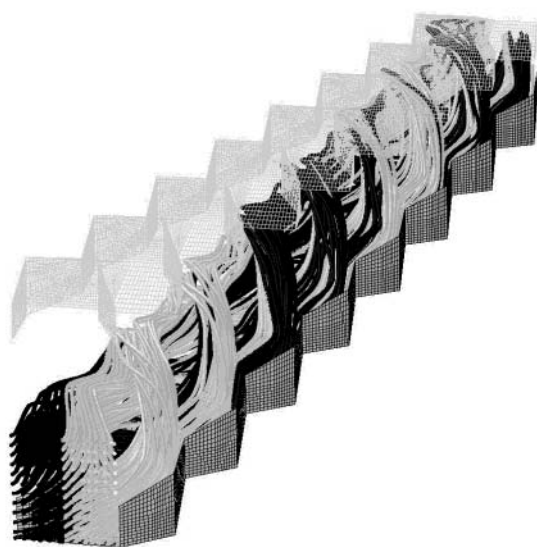

Figure 8. CFD simulation of streamlines in the caterpillar minimixer: 1 m/s; 5.2 L/h; $Re = 1200$.

the caterpillar minimixer. The maximum yield of 89% obtained with the laboratory configuration using the caterpillar mixer could be confirmed also with the pilot-scale configuration equipped with the same device (see Table 9). The corresponding experiments, carried out at 10, 20, 30, and 40 °C with residence times of 1, 5, 10, 26, and 120 s,

Table 9. Yields obtained for the target product and side/consecutive products of the *Phenyl Boronic Acid Process* using the pilot-scale configuration with the caterpillar steel minimixer

temperature	10 °C				20 °C				30 °C				40 °C		
	residence time [s]				residence time [s]				residence time [s]				residence time [s]		
	6	10	26	120	6	10	26	120	1	6	10	26	1	6	10
P1	85.8	89.2	85.8	86.1	90–95 ^a	90–95 ^a	75.8	90–95*	71.1	76.7	77.0	75.9	79.0	56.6	22.4
C1	0.0	0.0	0.0	0.0	0.0	0.0	0.0	0.0	0.0	0.0	0.0	0.0	0.0	0.0	0.0
S2	4.9	4.9	5.8	5.6	5.6	7.0	5.5	5.9	6.3	5.1	5.1	4.8	5.2	5.5	6.1
S1	0.0	0.0	0.0	0.0	0.0	0.0	0.0	0.0	0.0	0.0	0.0	0.0	0.0	0.0	0.0
S3	0.0	0.0	0.0	0.0	0.0	0.0	0.0	0.0	0.0	0.0	0.0	0.0	0.0	0.0	0.0
S4	0.0	0.0	0.0	0.0	0.0	0.0	0.0	0.0	0.0	0.0	0.0	0.0	0.0	0.0	0.0

^a Above 90% yield the accuracy of the HPLC measurements was lower, i.e., indicating typically too high yields resulting in dissonant overall balances of the product and by-products, probably due to insufficient calibration in this region. These data were corrected to the range shown to give reasonable overall balances.

however, did not exceed that value. The best result was achieved at 10 °C und 10 s.

Moreover, the results show that even for long residence times (about 4 times longer as for the laboratory configuration) and tubes of large inner diameter, no significant decrease of yield was observed at the two lowest temperatures applied, 10 and 20 °C. In a broader perspective, this also elegantly shows that hybrid systems, composed of microfluidic components and conventional equipment, are suitable solutions for process intensification of, at least, certain fast organic reactions.

Only one experiment with the pilot-scale configuration showed a considerable decrease in yield. At a temperature of 40 °C and a residence time of 10 s a decrease of yield to 22% was observed. The steel tube employed for this experiment had an inner diameter of 4.8 mm which roughly is equivalent to the channel diameter of the caterpillar mixer, however, not to its internal microstructures. The results get even worse when a still larger tube (i.d.: 9.3 mm) is used. Plugging was observed when operating at a temperature of 40 °C despite the flow guidance through a large tube. Plugging occurred neither at 30 °C with a residence time of 26 s nor at 20 °C and 120 s.

Generally, a much larger dependency of yield on temperature was observed for the experiments with pilot-scale configuration as compared to the laboratory configuration, probably for reasons of worse mass- and heat transfer (see Figure 9).

The yield of the side and consecutive products was small when using the pilot-scale configuration, in agreement with the experiments using the laboratory configuration with the caterpillar mixer.

5. Conclusions

The replacement of a former batch process by a continuous-flow process with microfluidic devices results in a notable process intensification for the *Phenyl Boronic Acid*

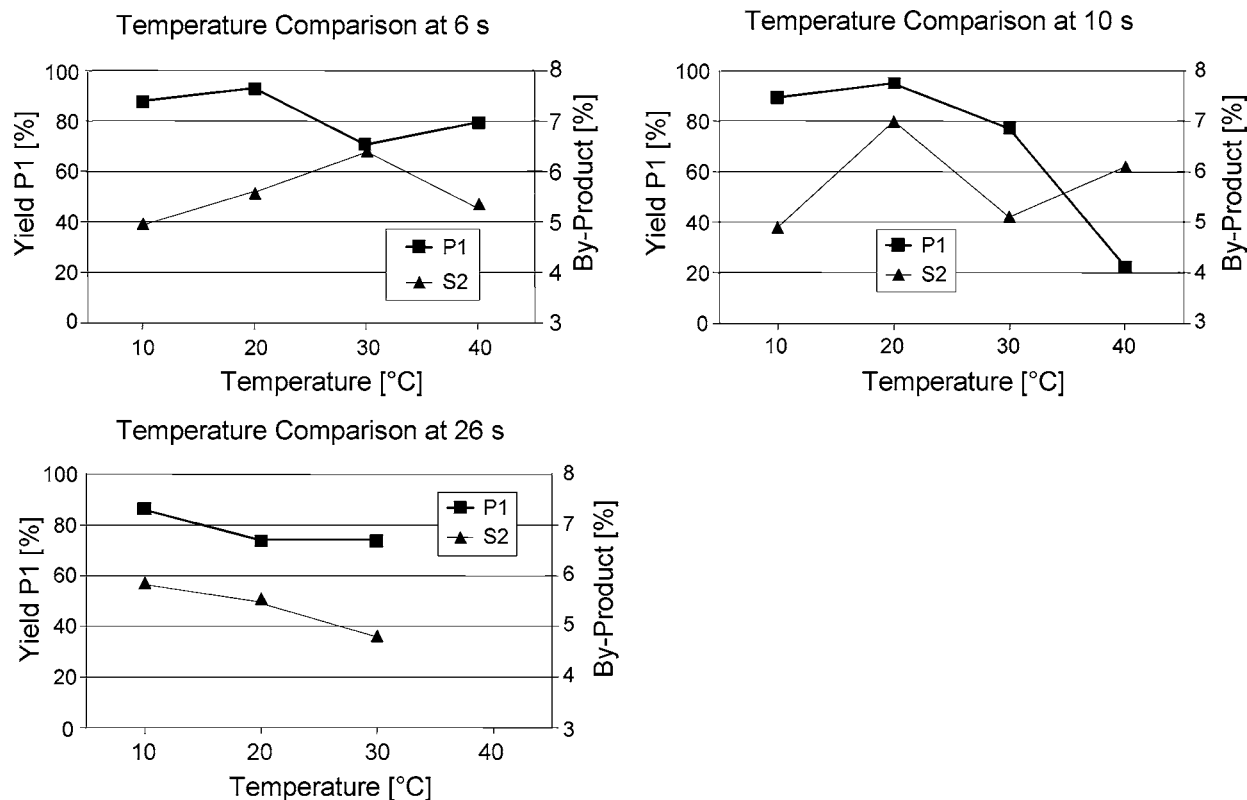

Figure 9. Yield of products as a function of volumetric flow rate, respectively residence time for the pilot-scale configuration with the caterpillar steel minimixer.

Process with regard to product yield, reduction of side/consecutive products, and energy expenditure.

The best result of the investigations was an HPLC yield of 89% (preparatively confirmed: 81%). This is nearly 25% higher as compared to the established *Phenyl Boronic Acid Process*, when being industrially performed in a batch-wise manner, and about 18% more than the laboratory-scale batch. The side- and consecutive products are reduced to levels below 1%, thereby increasing selectivity and facilitating separation by elimination of the distillation step. As a result, a product of higher purity (~99%) is achieved.

Instead of having three heating-cooling cycles, the microreactor operation needs only one heating-cooling cycle with considerably reduced temperature differences; the latter basically because of increasing the reaction temperature from cryogenic to ambient (see Figure 10). Using the laboratory configuration with the triangular micromixer even a temperature of 50 °C could be used, if desired, without any notable decrease in yield. In a broader view, this is another confirmation that microdevices allow a much higher variability regarding process temperature as compared to conventional reactors.

The small dependency of the yield on either the volumetric flow rate or on the temperature when using the laboratory-scale configuration is advantageous with regard to process control. A small deviation of these parameters during operation, for some reason, will not cause a loss of the process benefits. However, this positive feature is lost to a larger extent when using the pilot-scale configuration. This shows that the micro- and mini-approach have their own

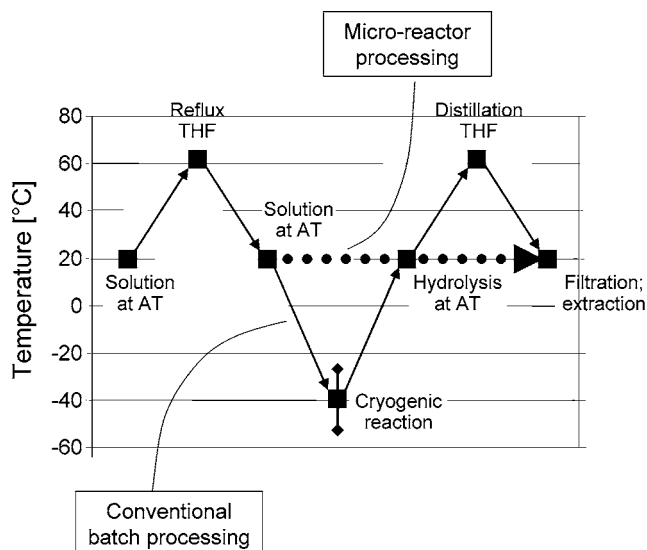

Figure 10. Temperature levels due to the need of heating and cooling for *Phenyl Boronic Acid Process*. (a) Conventional batch process; (b) novel microreactor process.

distinct advantages and drawbacks. In some cases, such as here, they are thereby complementary.

Using the minimixer already at the laboratory stage, favourably high throughputs of 10 L/h could be achieved which facilitated preparative confirmation of the analytical results. In addition, thereby a fast transfer of the results to scale-up investigations using the pilot-scale configuration was achieved already at present. A throughput of 10 L/h enables a production of about 6 kg of phenyl boronic acid per day. With pumps of higher-pumping capacity as used in the

investigations described herein, a throughput of 100 L/h is achievable with the caterpillar mixer, equivalent to a production of 20 tons of product per year.

Last but not least, the results show that fouling-sensitive reactions and microreactors are by no means a contradiction if optimal internal dimensions are chosen appropriately, if sufficient hydrodynamic information is available, and if compromises concerning setting of process parameters are acceptable. This positive interplay of circumstances certainly

has its severe limits, but presently the possibilities of using microfluidic devices for such a processing, albeit far from being optimal at present, seem by far not to be exploited. This technique displays great potential for a broader application.

Received for review November 28, 2003.

OP0341768